

ORIONTM
ORIONTM
HIGH PERFORMANCE CAR AUDIO

OWNER'S MANUAL

Amplifier

MODEL
C0300.2
C0600.2



TABLE OF CONTENTS

- English 1
- Français 15
- Español..... 25
- Deutsche 35
- Italiano..... 45
- Português 55

- Introduction..... 2
- What's in the Box 2
- Practice Safe Sound™..... 2
- Tools of the Trade..... 2
- End Panel Layouts..... 3
- CEA Specifications..... 5
- Amplifier Settings..... 5
 - Signal Input and Output Configurations 5
 - Input Gain 5
 - Internal Crossover 6
 - Low Pass Crossover 6
 - High Pass Crossover 6
- Amplifier Wiring..... 6
 - Power Connections for the Orion Cobalt CO300.2 and CO600.2 6
 - Speaker Connections 6
 - Tri-mode..... 7
 - Bridging..... 7
- Amplifier Installation 7
 - Choosing Mounting Locations..... 7
 - Passenger Compartment 8
 - Trunk Compartment 8
 - General Precautions and Installation Tips..... 8
 - Step By Step Installation..... 9
- Set Up and Troubleshooting 9
 - Testing the System 9
 - Adjusting the Sound of the System..... 10
 - Troubleshooting Tips 11
- Specifications..... 13
- Warranty Back cover

INTRODUCTION

Thank you for your purchase of a Orion Cobalt power amplifier. Each Orion Cobalt amplifier is designed to be the leader in its class offering the most power, advanced features, and extreme ease of use. In high-end sound systems or high SPL systems, Orion Cobalt amplifiers will give you years of trouble-free performance.

- **CO300.2 - 150 Watt** - two-channel Class A/B amplifier with built-in fully variable high and low-pass crossover. The CO300.2 is capable of one-channel operation with a maximum power of 300 W into 4 ohms.
- **CO600.2 - 300 Watt** - two-channel Class A/B amplifier with built-in fully variable high and low-pass crossover. The CO600.2 is capable of one-channel operation with a maximum power of 600 Watts into 4 ohms.

The installation of all Orion Cobalt components will determine the overall performance result. Improper installation will not only limit the performance of your Orion Cobalt system but also potentially compromise the reliability of this amplifier. To ensure proper sonic results and component reliability, please refer to your authorized dealer for installation assistance or advice. If you decide to perform the installation yourself, be sure to read the entire manual before beginning the installation.

WHAT'S IN THE BOX

- (1) Amplifier
- (2) Spare fuse(s)
- (4) #8 self-tapping black Phillips head pan head screws
- (1) Amplifier installation and operation manual

PRACTICE SAFE SOUND™

Continuous exposure to sound pressure levels over 100dB may cause permanent hearing loss. High power automotive sound systems can generate sound pressure levels in excess of 130dB. When playing your system at high levels, please use hearing protection and avoid long term exposure.

Model: _____

Serial Number: _____

Date of Purchase: _____

TOOLS OF THE TRADE

Listed next are the majority of the tools required to perform an installation. Having the proper tools will make the installation that much easier. Some of these tools are necessities; some will just make the job easier.

- Allen Wrenches (2mm, 3mm and 4mm)
- Electric drill with assorted drill bits
- Heat shrink tubing
- Phillips and flat blade screw drivers
- Pliers (standard and needle nose)
- RTA (real time analyzer)
- Soldering iron and solder
- Utility knife
- Wire brush or sandpaper for chassis grounding
- Reference CD with 1 kHz Sine Wave at 0dB level (all bits high)
- DMM or VOM
- Grommets
- Marking pen
- Nylon tie straps
- Wire crimper
- Wire cutters
- Wire strippers

END PANEL LAYOUTS

Input Plate

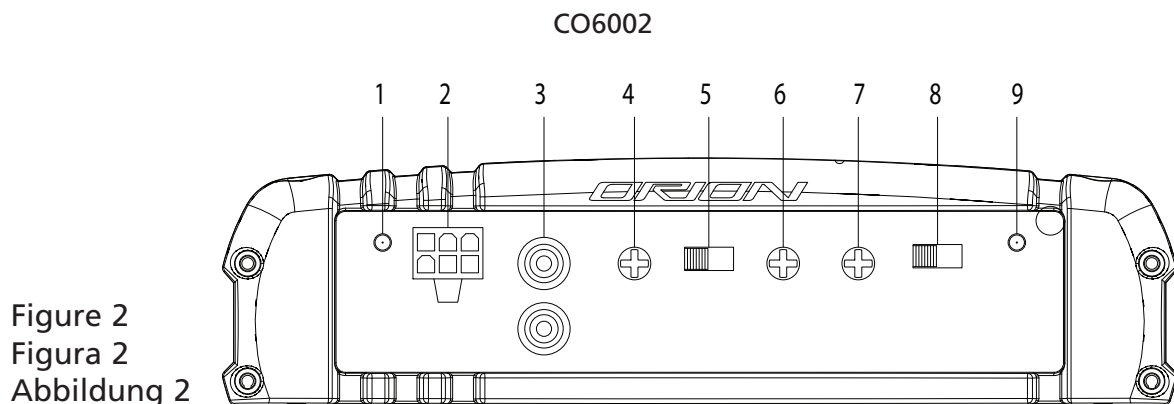
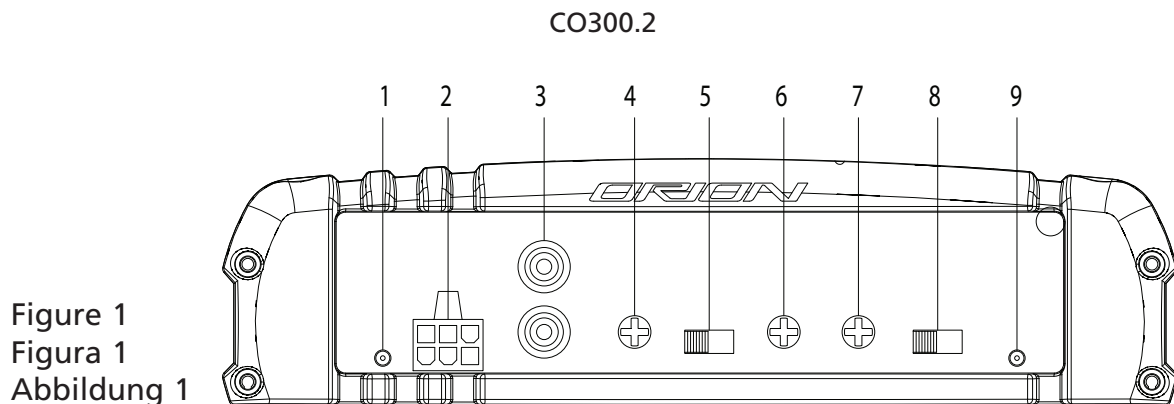

1. **Power LED** - When lit indicates that the amplifier is on.
2. **High Level Input** - Connect speaker output from factory radio to amplifier, will auto sense signal from radio and turn amplifier on when needed, turn off after 1 minute

without signal.

3. **RCA Inputs** - Accepts RCA input from a source unit, preamplifier, or equalizer.
4. **Gain Control** - Continuously adjusts from 175mV to 8V input to obtain full power output.
5. **HPF, FULL, LPF Switch** - Selects either Hi-pass crossover, Full range, or Lo-pass crossover.
6. **Lo-Pass Frequency Control** - Adjusts the frequency of the crossover.
7. **Hi-Pass Frequency Control** - Adjusts the frequency of the crossover.
8. **Bass Boost Switch** - Adjusts bass gain in three steps (0dB, 6dB, & 12dB).
9. **Status LED** - Will indicate any fault condition in amplifier, also lights briefly during muting phase of turn-on

Output Plate

CO300.2

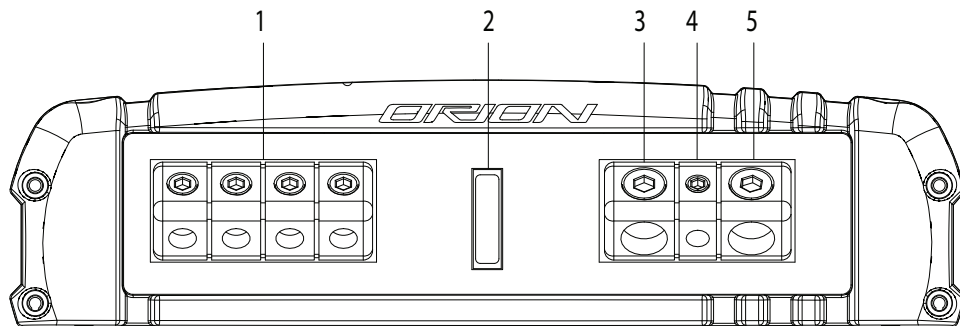

Figure 3
Figura 3
Abbildung 3

CO600.2

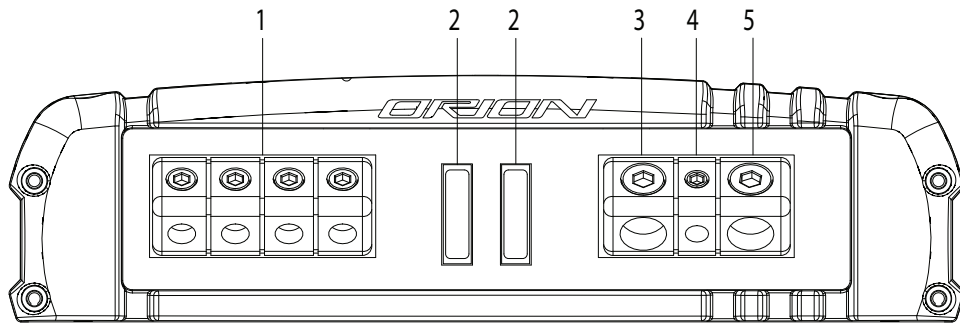

Figure 4
Figura 4
Abbildung 4

1. **Speaker Connections** - accepts up to 12 AWG speaker wire.
2. **1 ATC Fuse (CO300.2) - 2 ATC Fuses (CO600.2)** - protects the amplifier from over current situations.
3. **Power Connections** - accepts up to 4 AWG power cables.
4. **REM Remote Turn-on Input** - turns on the amplifier when fed 12 V+.
5. **Ground Connection** - accepts up to 4 AWG ground cable.

CEA SPECIFICATIONS

CO300.2



Power Output: 60 Watts RMS x 2 at 4 ohms and < 1% THD+N
Signal to Noise Ratio: -75 dBA (reference Watt into 4 ohms)
Additional Power: 80 Watts RMS x 2 at 2 ohm and < 1% THD+N

CO600.2



Power Output: 100 Watts RMS x 2 at 4 ohms and < 1% THD+N
Signal to Noise Ratio: -75 dBA (reference Watt into 4 ohms)
Additional Power: 155 Watts RMS x 2 at 2 ohm and < 1% THD+N

HIGH LEVEL HARNESSSES

Do not connect the high level input connections to power, signal, or chassis ground as damage to the head-unit outputs may result. The high-level inputs are designed to work with either grounded or BTL speaker level outputs (found on most head units).

HIGH LEVEL CONNECTIONS

WIRE COLOR	INPUT CONNECTION
Black	Ground
White/Black	- Left channel
White	+ Left channel
Gray/Black	- Right channel
Gray	+ Right channel

AMPLIFIER SETTINGS

Signal Input and Output Configurations

The input section of the amplifier consists of a phase switch that sets the output configuration, gain controls, and RCA inputs. The input section makes it easy to adapt this amplifier to most system configurations.

Input Gain

The Orion Cobalt CO300.2 and CO600.2 amplifiers have level adjustments to allow for easy integration with any source unit. The input sensitivity can be adjusted from 175mV to 8V. Refer to *Testing the System* and *Adjusting the Sound of the System* sections of this guide for detailed instructions on setting the gain.

Internal Crossover

The crossover section of the Orion Cobalt CO300.2 and CO600.2 amplifiers is continuously variable and extremely flexible.

When using Orion Cobalt loudspeakers, minor deviations from the recommended frequency ranges can provide superior results depending on your speaker locations and your vehicle acoustics. Setting crossover frequencies higher than recommended will not cause damage and may provide superior sonic results depending on your system's performance goals. Refer to your loudspeaker owner's manual for assistance in choosing the proper crossover frequencies for your system.

Low-Pass Crossover

The low-pass crossover is active with a 2nd order (12dB per octave) slope. The low-pass crossover is continuously variable from 50Hz to 500Hz.

High-Pass Crossover

When the switch is to the left (FULL position), the high-pass crossover is bypassed. When the switch is to the right (HPF position), the high-pass crossover is active. The high-pass crossover is continuously variable from 50Hz to 500Hz.

AMPLIFIER WIRING

Power Connections for the Orion Cobalt CO300.2 and CO600.2

- Orion Cobalt CO300.2 Fuse Size: 1 x 25 AMP ATC / CO600.2 Fuse Size: 2 x 20 AMP ATC
- Power connections accept up to 4 AWG wire.
- 4 AWG power and ground wire recommended for optimal performance.
- Connect 12V+ to the battery through fuse holder. This connection provides +12V main power to the amplifier.
- Power wire must be fused no more than 18" from battery.
- Ground amplifier to a good chassis ground as close as possible to the amplifier.
- Connect REM terminal to remote turn-on lead from source unit. This connection provides +12V power to turn-on the amplifier.
- Add extra ground wire between the negative terminal of the battery and the chassis.

Speaker Wiring Diagram CO300.1/CO600.2

The Orion Cobalt CO300.2 and CO600.2 amplifiers offer two positive and two negative output terminals for ease of connecting the speakers to the amplifier. Each amplifier is stable to 2Ω per channel or 4 ohm bridged .

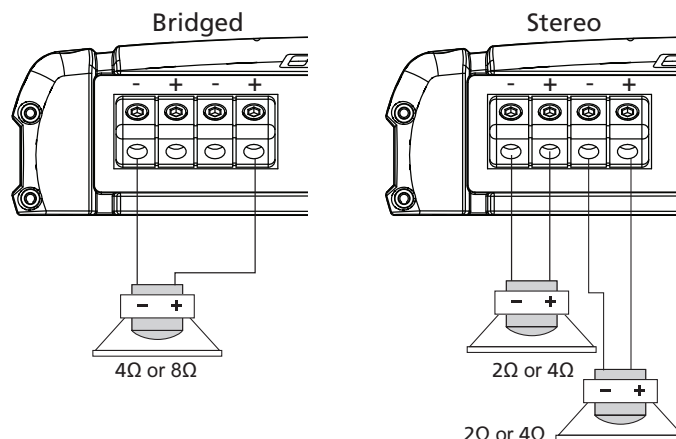

Figure 5
Figura 5
Abbildung 5

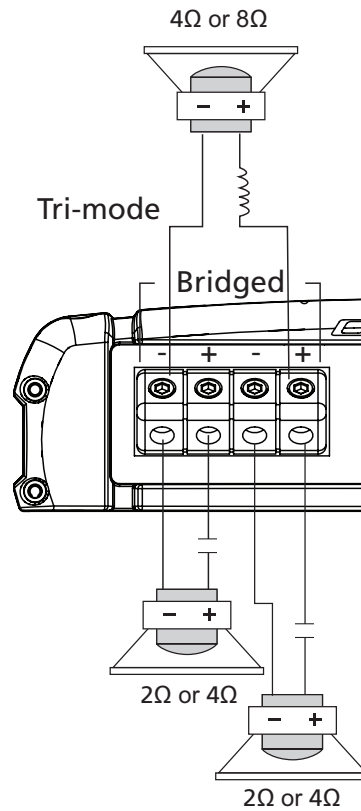

Figure 6
 Figura 6
 Abbildung 6

Tri-mode

For Tri-mode wiring the high frequency speakers should be run in stereo and use a passive in line crossover (capacitor) with each to remove the low frequency. The mono low frequency speaker would be connected in the bridge mode to the two stereo channels with a in line passive crossover (inductor) to remove the high frequencies. The high frequency speakers should be no less than 2 ohms and the low frequency speaker should be no less than 4 ohms.

Bridging

For bridging into a single speaker load, the Orion Cobalt CO300.2 and CO600.2 has the ability to bridge the front or rear channels together. The impedance of the speaker must not be less than 4Ω

AMPLIFIER INSTALLATION

Choosing Mounting Locations

The location of your amplifier will depend on several important issues. Due to the low profile size of the Orion Cobalt amplifiers, there are many possible installation locations that will yield satisfactory amplifier performance. Always mount the amplifier in a place that protects the amplifier from the elements. In addition, mount the amplifier on a stable, flat surface.

NOTE: Mounting amplifiers upside down is not recommended and may cause premature thermal shutdown.

WARNING! Do not mount any amplifier in the engine compartment. Amplifiers are not designed to endure the harsh environment of the exterior elements.

Passenger Compartment

If you are going to mount the amplifier in the passenger compartment, make sure you have adequate room for ventilation. The amplifiers have been designed to make under-seat mounting possible. When mounting your amplifier under a seat or similar area, keep a minimum of 1" of clearance around the amplifier for adequate cooling.

Trunk Compartment

Mounting your amplifier in the trunk provides excellent performance as long as you do not restrict the airflow around the heatsink of the amplifier. For optimal results, mount the amplifier with as much clearance as possible. This type of mounting will yield the best cooling due to the convection effect of the amplifier chassis.

General Precautions and Installation Tips

WARNING! Be careful not to cut or drill into gas tanks, fuel lines, brake lines, hydraulic lines, vacuum lines, or electrical wiring when working on your vehicle.

Disconnect the vehicle's ground wire at the battery before making or breaking connections to the audio system's power supply terminals.

Do not use this amplifier unmounted. Failing to securely mount the amplifier can result in damage or injury, particularly in the event of an accident. An unmounted amplifier becomes a dangerous projectile in the event of a crash. Never mount the amplifier where it might get wet. Mount the amplifier so the wire connections will not be pulled. Route the wires where they will not be scraped, pinched or damaged in any fashion.

The +12V power supply wire must be fused as close as possible to the battery terminal, ideally within 18". Use the recommended fuse size or circuit breaker listed in the *Power Connections* section of this manual.

If you need to replace the fuse plugged into the side of the amplifier, replace the fuse with the same size ATC / MAXI type fuse that came with the amplifier. If you are not sure as to the correct value, refer to the *Power Connections* section of this manual for details. Using a higher current fuse may result in damage to the amplifier that is not covered under warranty.

NOTE: Make sure all the equipment in the system is turned off when making or breaking connections to the input RCAs or speaker terminals. Turn on the system and slowly turn up the volume control only after double checking all wire connections.

Power for systems with a single amplifier can be supplied by most automotive electrical systems. Systems with multiple amplifiers may require a higher capacity battery, alternator or the use of a storage capacitor. We strongly recommend the use of a Directed Audio Essentials power capacitor with an extra battery in larger stereo systems.

Orion Cobalt amplifiers generate a certain amount of heat as part of normal operation. Be sure the area around the amplifier is unobstructed to allow adequate air circulation. Remember, beach blankets, last week's laundry, school books and homework papers located on top of the amplifier do not improve air flow and may become damaged.

Step By Step Installation

- Step 1 Determine the location for the amplifier. Refer to the *Choosing Mounting Locations* section of this guide for detailed information.
- Step 2 Decide on the system configuration for your amplifier. For system suggestions, refer to the *Speaker Connections* section of this guide.

- Step 3 Run all the wires from the amplifier location to the speakers, source unit, and battery. Do not connect the battery at this time. Be sure to run RCAs and power and speaker wires away from factory electrical wires and system as they pose a great potential for induced system noise.
- Step 4 Pre-drill amplifier mounting holes. Be sure to "think before you drill". Gas tanks, fuel lines, and other obstructions have a nasty way of hiding themselves. For best results use a marking pen to mark the mounting holes and pre-drill these holes with a standard 1/8" drill bit.
- Step 5 Mount the amplifier. Make sure the amplifier is mounted on a flat surface. If this is not possible, do not over tighten the screws so that the chassis of the amplifier is twisted or bent.
- Step 6 Turn the vehicle's key switch to the off position.
- Step 7 Disconnect the vehicle's battery ground terminal.
- Step 8 Connect power wires to the amplifier (ground first, then 12 V(+) and REM).
- Step 9 Connect the RCA and speaker wires to the amplifier. Check the quality of your speakers and signal connections. This will determine the ultimate performance of your Orion Cobalt amplifier. Refer to the *Signal Input and Output Level Controls* and *Speaker Connections* sections of this guide for correct wiring instructions.
- Step 10 Reconnect the ground terminal to the battery after power, speaker, and RCA connections are completed.
- Step 11 Set crossovers. Refer to the *Internal Crossover Configuration* section of this manual for detailed instructions.
- Step 12 Once satisfied that all connections and settings are correct, install the fuse located near the vehicle's battery and proceed to the *Testing the System* section of this manual.

WARNING! Never exceed the recommended fuse size of this amplifier. Failure to do so will result in the voiding of your warranty and possible damage to the amplifier.

SET UP AND TROUBLESHOOTING

Testing the System

After you have completed the installation, you need to test the system. This will help ensure years of trouble-free operation. Please refer to the listed steps below when testing the sound of your Orion Cobalt system.

- Step 1 Check all the wiring connections to be sure they are correct and secure.
- Step 2 Turn the signal source volume control all the way down. Set any tone controls to their flat or defeated positions. This includes the loudness control.
- Step 3 Turn the level controls of the amplifier to their minimum positions.
- Step 4 Turn the source unit on. Check to see if the power LED located on the input side of the amplifier is on. If not, please refer to the *Power Connections* and the *Troubleshooting Tips* sections of this manual for instructions.
- Step 5 If using an aftermarket source unit, turn the level controls of the amplifier about one quarter of a turn. Slowly increase the volume level of the source unit to so that you can hear the output of the system. If no sound is heard or if the output is distorted, turn the system off immediately. Refer to the *Power Connections* and the *Troubleshooting Tips* sections of this manual to solve your installation problems.
- Step 6 Check to make sure the output for each channel is correct. If the active crossovers

are used, check to make sure that each output is correct from the amplifier. When using active crossovers on midrange and tweeters, do not use crossover frequencies lower than recommended. If the system is not configured properly, refer to the *Internal Crossover Configuration* section of this manual and take corrective action.

- Step 7 If the output is clear and undistorted, continue to the *Adjusting the Sound of the System* section of this manual.

Adjusting the Sound of the System

Once you have checked the system's operation, adjust the sound of the system. Adjusting the sound of the system is accomplished by setting the level controls and adjusting the internal crossovers.

- Step 1 Turn the signal source volume control all the way down. Set any tone controls to their flat or defeated positions. This includes the loudness control.
- Step 2 Turn the level controls of the amplifier to their minimum positions.
- Step 3 Choose music with high dynamic content that you like, with which you are familiar, and will be used most often in the system.
- Step 4 Turn the source unit's volume control up to its highest undistorted output level. If you lack test equipment, this point occurs between 3/4 to full volume depending on the quality of your source unit. Listen for any audible distortion. If any distortion is audible, reduce the volume of the source unit until you have an undistorted output. Leave the volume control at this position during your system tuning.
- Step 5 While listening to your chosen dynamic music, turn up the level control corresponding to the midrange output until you hear slight distortion and turn the level control back slightly for an undistorted output. Depending on your system, the midrange and tweeter output may be on the same output channels.
- Step 6 Turn up the level control corresponding to the tweeter output until you hear slight distortion and turn back the level control slightly for an undistorted output. Depending on your system the midrange and tweeter output may be on the same output channels.
- Step 7 Fine-tune the output level between midrange and tweeters. Refer to the *Internal Crossover Configuration* section of this manual for detailed instructions.
- Step 8 Repeat Steps 5-7 for the rear speakers. If you do not have rear speakers continue to Step 10.
- Step 9 Set levels between the front and rear midrange and tweeters for optimum front/rear balance.
- Step 10 Turn up the level control corresponding to the woofer output until you hear slight distortion and turn back the level control slightly for an undistorted output.
- Step 11 Fine-tune the output level between satellite speakers and the woofers. Refer to the *Internal Crossover Configuration* section of this manual for detailed instructions.
- Step 12 Enjoy your awesome Orion Cobalt sound system.

Troubleshooting Tips

Symptom	Probable Cause	Action To Take
No output		
	Low or no remote turn-on	Check remote turn-on voltage at voltage amplifier and repair as needed.
	Fuse blown	Check power wire's integrity and check for speaker shorts. Fix as needed and replace fuse.
	Power wires not connected	Check power wire and ground connections and repair or replace as needed.
	Audio input not connected.	Check RCA connections and repair or replace as needed.
	Speaker wires not connected	Check speaker wires and repair or replace as needed.
	Speaker are blown	Check system with known working speaker and repair or replace speakers as needed.
Audio cycles on and off		
	Thermal protection engages when amplifier heat sink temperature exceeds 50° C (122° F)	Make sure there is proper ventilation for amplifier and improve ventilation as needed.
	Loose or poor audio input	Check RCA connections and repair or replace as needed.
	Loose power connections	Check power wires and ground connections and repair or replace as needed.
Distorted output		
	Amplifier level sensitivity set too high exceeding maximum capability of amplifier	Readjust gain. Refer to the <i>Adjusting the Sound of the System</i> section of this manual for detailed instructions.
	Impedance load to amplifier too low	Check speaker impedance load, if below 2Ω, rewire the speakers to achieve higher impedance.
	Shorted speaker wires	Check speaker wires and repair or replace as needed.
	Speaker not connected to amplifier properly.	Check speaker wires and repair or replace as needed. Refer to the <i>Speaker Connections</i> section of this manual for detailed instructions
	Internal crossover not set properly for speakers	Readjust crossovers. Refer to the <i>Internal Crossover Configuration</i> section of this manual for detailed instructions.
	Speakers are blown	Check system with known working speakers and fix or replace as needed.
Poor bass response		
	Speakers wired with wrong polarity causing cancellation at low frequencies.	Check speaker polarity and fix as needed.

Symptom	Probable Cause	Action To Take
Poor bass response		
	Crossover set incorrectly	Reset crossovers. Refer to the <i>Internal Crossover Configuration</i> section of this manual for detailed instructions.
	Impedance load at amplifier is too low.	Check speaker impedance load if below 2Ω, rewire speakers to achieve higher impedance .
Battery fuse blowing		
	Short in power wire or incorrect wiring.	Check power wires and ground connections and repair or replace as needed.
	Fuse used is smaller than recommended.	Replace with proper fuse size.
	Actual current exceeds fuse rating.	Check speaker impedance load if below 2Ω, rewire speakers to achieve higher impedance .
Amplifier fuse blowing		
	Fuse used is smaller than recommended.	Replace with proper fuse size.
	Impedance load at amplifier is too low.	Check speaker impedance load if below 2Ω, rewire speakers to achieve higher impedance .
	Speaker is blown with shorted outputs	Check system with known working speakers and fix or replace as needed.
	Actual current exceeds fuse rating	Check speaker impedance load if below 2Ω, rewire speakers to achieve higher impedance .

SPECIFICATIONS

Amplifier Section	CO300.2	CO600.2
Power Output in Watts RMS, 4 Ohms	60 x 2	100 x 2
Power Output in Watts RMS, 2 Ohms	80 x 2	155 x 2
Distortion at Rated Power	< 0.5% THD+N	< 0.7% THD+N
Frequency Response	20Hz to 30kHz +/-0.5dB	20Hz to 30kHz +/-0.5dB
Linear Bandwidth	20Hz to 20kHz ±3dB	20Hz to 20kHz ±3dB
Damping Factor	> 100	> 100
Input Sensitivity	175mV - 8V	175mV - 8V
Input Impedance	> 15kΩ	> 10kΩ
Fuse Type	(1) 25 Amp, ATC	(2) 20 Amp, ATC
Dimensions	2.1" x 8.1" x 7.9"	2.1" x 8.1" x 11.4"
Weight	4.5 lbs.	6.3 lbs.
Crossover Section		
Low Pass and Hi-pass crossover	Continuously variable/ 2nd Order	Continuously variable/ 2nd Order
Crossover Frequency Range	50Hz to 500Hz	50Hz to 500Hz

Continuous 2Ω load 20Hz to 200Hz, < 0.1% THD, with input voltage at 13.8VDC

WARRANTY



LIMITED ONE-YEAR CONSUMER WARRANTY/*LIMITED TWO-YEAR CONSUMER WARRANTY FOR AUTHORIZED DIRECTED DEALER PURCHASE & INSTALLATION

Directed Electronics (herein "Directed") promises to the original purchaser of the subwoofer or amplifier, as applicable (herein "Unit" or "Product"), to repair or replace with a new or refurbished Unit (at Directed's sole and absolute discretion) should the Unit prove to be defective in workmanship or material under normal use, for a period of *two-years from the date of purchase from the authorized Directed dealer PROVIDED the Unit was purchased and installed by an authorized Directed dealer. During this *two-year period, there will be no charge for the repair or replacement PROVIDED the Unit is returned to Directed (DO NOT RETURN THE ENTIRE ENCLOSURE. PLEASE RETURN THE WARRANTIED UNIT ONLY.), shipping prepaid, along with the required proof of installation, the bill of sale or other dated proof of purchase, and the consumer's contact information. If the Unit is installed by anyone other than an authorized Directed dealer, the warranty period will be one-year from the date of purchase. This warranty is non-transferable and does not apply to any Unit that has been modified or used in a manner contrary to its intended purpose, and does not cover damage to the Unit caused by installation or removal of the Unit. During this one-year period, there will be no charge for the repair or replacement PROVIDED the Unit is returned to Directed, shipping pre-paid, along with the bill of sale or other dated proof of purchase and the consumer's contact information. This warranty is void if the product has been damaged by accident or unreasonable use, neglect, improper service or other causes not arising out of defects in materials or construction. This warranty does not cover the elimination of externally generated static or noise, or the correction of antenna problems or weak reception, damage to speakers, accessories, electrical systems, cosmetic damage or damage due to negligence, misuse, failure to follow operating instructions, accidental spills or customer applied cleaners, damage due to environmental causes such as floods, airborne fallout, chemicals, salt, hail, lightning or extreme temperatures, damage due to accidents, road hazards, fire, theft, loss or vandalism, damage due to improper connection to equipment of another manufacturer, modification of existing equipment, or Product which has been opened or tampered for any reason. Units which are found to be damaged by abuse resulting in thermally damaged voice coils are not covered by this warranty but may be replaced at the absolute and sole discretion of Directed. Unit must be returned to Directed (DO NOT RETURN THE ENTIRE ENCLOSURE. THE UNIT ENCLOSURE IS COVERED BY A SEPARATE 90-DAY LIMITED CONSUMER WARRANTY. PLEASE ONLY RETURN THE WARRANTIED UNIT UNLESS A WARRANTY CLAIM IS BEING MADE FOR THE ENCLOSURE.), postage pre-paid, with bill of sale or other dated proof of purchase bearing the following information: consumer's name, telephone number, and address, authorized dealer's name and address, and product description. Unit must be returned to the following address: ATTN: WARRANTY DEPARTMENT, Directed Electronics, 1 Viper Way, Vista, CA 92081. Note: This warranty does not cover labor costs for the removal and/or reinstallation of the Unit. IN ORDER FOR THE TWO-YEAR WARRANTY TO BE VALID, YOUR UNIT MUST BE SHIPPED WITH PROOF OF INSTALLATION BY AN AUTHORIZED DIRECTED DEALER. ALL UNITS RECEIVED BY DIRECTED FOR WARRANTY REPAIR WITHOUT PROOF OF DIRECTED DEALER INSTALLATION AND PURCHASE WILL BE COVERED BY THE LIMITED 1 YEAR WARRANTY.

BY PURCHASING THIS PRODUCT, ALL WARRANTIES INCLUDING BUT NOT LIMITED TO EXPRESS WARRANTY, IMPLIED WARRANTY, WARRANTY OF MERCHANTABILITY, FITNESS FOR PARTICULAR PURPOSE, AND WARRANTY OF NON-INFRINGEMENT OF INTELLECTUAL PROPERTY ARE EXPRESSLY EXCLUDED TO THE MAXIMUM EXTENT ALLOWED BY LAW, AND DIRECTED NEITHER ASSUMES NOR AUTHORIZES ANY PERSON TO ASSUME FOR IT ANY LIABILITY IN CONNECTION WITH THE SALE OF THE PRODUCT. DIRECTED HAS ABSOLUTELY NO LIABILITY FOR ANY AND ALL ACTS OF THIRD PARTIES INCLUDING ITS AUTHORIZED DEALERS OR INSTALLERS. IN NO EVENT WILL DIRECTED BE LIABLE FOR ANY INCIDENTAL, SPECIAL OR CONSEQUENTIAL DAMAGES (INCLUDING LOSS OF PROFITS). BY PURCHASING THIS PRODUCT, THE CONSUMER AGREES AND CONSENTS THAT ALL DISPUTES BETWEEN THE CONSUMER AND DIRECTED SHALL BE RESOLVED IN ACCORDANCE WITH CALIFORNIA LAWS IN SAN DIEGO COUNTY, CALIFORNIA. This warranty is only valid for sale of Product within the United States of America. Product sold outside of the United States of America is sold "AS-IS," and shall have NO WARRANTY, express or implied. Some states do not allow limitation on how long an implied warranty lasts. In such states, the limitation or exclusions of this Limited Warranty may not apply. Some states do not allow the exclusion or limitation of incidental or consequential damages. In such states, the exclusion or limitation of this Limited Warranty may not apply to you. This Limited Warranty gives you specific legal rights, and you may have other rights which vary from state to state. 920-0033 04-07

For more information on Orion or WCC products please visit www.orioncaraudio.com



Directed Electronics is an ISO 9001 registered company.

Directed Electronics is committed to delivering world class quality products and services that excite and delight our customers.

distributed by
Directed
ELECTRONICS
Vista, CA 92801
DIRECTED.COM

1. Mr. 2. Mrs. 3. Ms. 4. Miss

XFA01-01

First Name _____ Initial _____ Last Name _____

Street _____ Apt. No. _____

City _____ State _____ ZIP Code _____

E-mail _____

2. Your date of birth: _____ / _____ / _____
Month Year
3. Marital status: 1. Married 2. Single
4. Date of purchase: _____ / _____ / _____
Month Day Year

5. Model number: _____
6. Name of store where purchased: _____

7. Price paid (excluding sales tax): \$ _____ .00

8. Which Directed Electronics brand did you purchase?

1. Directed Audio 4. Xtreme
2. Orion 5. a/d/s/
3. Precision Power 6. Directed Video

9. What product did you purchase?

1. Subwoofer 5. Complete Video System
2. Speaker 6. Overhead Monitor
3. Amplifier 7. Headrest Monitor
4. Signal Processor 8. DVD Player

10. What type of vehicle will this product be used in?

1. Car 6. Motorcycle
2. Truck 7. Boat
3. SUV 8. Motor home
4. Van 9. Other
5. MiniVan

11. In what vehicle will this product be used?

Make of vehicle: _____

Model name: _____

VIN #: _____

- Year: _____
- A. Bought New
B. Bought Used
C. Leased
D. Leased Used

12. How did you first become aware of this product? (check one)

01. Local newspaper 07. Radio commercial
02. Yellow pages 08. Salesperson's recommendation
03. Magazine advertisement 09. Motorsports sponsorship
04. TV commercial 10. Internet
05. Magazine article/review 11. Other
06. Friend/Relative's recommendation

13. What factors most influenced the purchase? (check up to three)

01. Directed's reputation 11. Style/Design/Color
02. Brand's reputation 12. Dealer proximity
03. Experience with Directed product 13. Friend's recommendation
04. Experience with dealer 14. Salesperson recommendation
05. Value/Price 15. Ease of installation
06. Warranty 16. Compatibility with vehicle
07. Special features 17. Other
08. Quality/Durability 18. Other Directed brands only
09. Sound board/in-vehicle demo
10. Rebate/Promotion

14. What benefits of this product most influenced your decision to purchase? (check up to three)

01. Improved sound quality 11. Increase vehicle value
02. Improved loudness/SPL 12. Functionality
03. Improved performance in vehicle 13. Warranty
04. Ability to watch movie in vehicle 14. Price/Value
05. Used by autosound competitors 16. Immediate availability
06. Compatibility with vehicle 17. Friend's recommendation
07. Ease of installation 18. Salesperson recommendation
08. Style/Design/Color 19. Dealer proximity
09. Special Features 20. Other
10. Quality/Durability

15. What other brands did you seriously consider before making this purchase?

01. None, only Directed Electronics Inc. 09. Polk Audio
02. Other Directed brands only 10. Audiobahn
03. Audiovox 11. Memphis
04. MTX 12. Kicker
05. MB Quart 13. Alpine
06. Rockford Fosgate 14. Sony
07. JL Audio 15. Kenwood
08. Rosen 16. Pioneer
17. Clarion
18. Other

16. Which of the following publications do you read regularly (three out of the last four issues)? (check all that apply)

01. Car and Driver 11. Road & Track
02. Car Audio & Electronics 12. Rolling Stone
03. Car Sound and Performance 13. SKATEboarding
04. Hot Boat 14. Ski
05. Import Tuner 15. Snowboard
06. Import Racer 16. Spin
07. Lowrider 17. Sport Compact Car
08. Mini Truckin' 18. Sport Truck
09. Motor Trend 19. Street Trucks
10. Performance Auto & Sound 20. Super Street
21. Truckin'
22. Working Woman
23. Other

17. Not including yourself, what is the GENDER and AGE (in years) of children and other adults living in your household?

1. No one else in household 2. Child under 1 year

Male	Female	Age	Male	Female	Age
1. <input type="checkbox"/>	2. <input type="checkbox"/>	yrs.	1. <input type="checkbox"/>	2. <input type="checkbox"/>	yrs.
1. <input type="checkbox"/>	2. <input type="checkbox"/>	yrs.	1. <input type="checkbox"/>	2. <input type="checkbox"/>	yrs.

18. Occupation: (check all that apply)

- | You | Spouse |
|---|-----------------------------|
| Professional/Technical..... <input type="checkbox"/> | 1. <input type="checkbox"/> |
| Upper Management/Executive..... <input type="checkbox"/> | 2. <input type="checkbox"/> |
| Middle Management..... <input type="checkbox"/> | 3. <input type="checkbox"/> |
| Sales/Marketing..... <input type="checkbox"/> | 4. <input type="checkbox"/> |
| Clerical/Service Worker..... <input type="checkbox"/> | 5. <input type="checkbox"/> |
| Tradesman/Machine Operator/Laborer.... <input type="checkbox"/> | 6. <input type="checkbox"/> |

19. Are you or your spouse:

- | You | Spouse |
|---|-----------------------------|
| A Homemaker?..... <input type="checkbox"/> | 1. <input type="checkbox"/> |
| Retired?..... <input type="checkbox"/> | 2. <input type="checkbox"/> |
| A Student?..... <input type="checkbox"/> | 3. <input type="checkbox"/> |
| Self Employed/Business Owner?..... <input type="checkbox"/> | 4. <input type="checkbox"/> |
| Working from a Home Office?..... <input type="checkbox"/> | 5. <input type="checkbox"/> |
| In the Military?..... <input type="checkbox"/> | 6. <input type="checkbox"/> |
| A Veteran?..... <input type="checkbox"/> | 7. <input type="checkbox"/> |

20. Which group describes your annual family income?

01. Under \$15,000 08. \$75,000-\$99,999
02. \$15,000-\$19,999 09. \$100,000-\$124,999
03. \$20,000-\$29,999 10. \$125,000-\$149,999
04. \$30,000-\$39,999 11. \$150,000-\$174,999
05. \$40,000-\$49,999 12. \$175,000-\$199,999
06. \$50,000-\$59,999 13. \$200,000-\$249,999
07. \$60,000-\$74,999 14. \$250,000 & over

21. Level of education: (check highest level completed)

1. Completed High School
2. Completed College
3. Completed Graduate School

22. Which credit cards do you use regularly?

1. American Express, Diners Club
2. MasterCard, Visa, Discover
3. Department Store, Oil Company, etc.
4. Do not use credit cards

23. For your primary residence, do you:

1. Own? 2. Rent?

24. How recently did you move into your current residence?

1. Within 30 days 4. 7 to 12 months ago
2. Within 1 - 3 months 5. Have not moved in the last 12 months
3. Within 4 - 6 months

25. Which of the following do you plan to do within the next 6 or 12 months?

- | | 1-6 Months | 7-12 Months |
|--|-----------------------------|-------------|
| Buy/Lease a New Vehicle..... <input type="checkbox"/> | 1. <input type="checkbox"/> | |
| Buy/Lease a Used Vehicle..... <input type="checkbox"/> | 2. <input type="checkbox"/> | |

26. Please check all that apply to your household.

- | | |
|---|--|
| 01. <input type="checkbox"/> Shop by Catalog/Mail | 07. <input type="checkbox"/> Have a Cat |
| 02. <input type="checkbox"/> Shop via the Internet | 08. <input type="checkbox"/> Own a Wireless/Cellular Phone |
| 03. <input type="checkbox"/> Member of Frequent Flyer Program | 09. <input type="checkbox"/> Subscribe to an Online/Internet Service |
| 04. <input type="checkbox"/> Donate to Charitable Causes | 10. <input type="checkbox"/> Speak Spanish |
| 05. <input type="checkbox"/> Own a Compact Disc Player | 11. <input type="checkbox"/> Own an Apple/Macintosh Computer |
| 06. <input type="checkbox"/> Have a Dog | 12. <input type="checkbox"/> Own a CD-ROM Drive |

27. To help us understand our customers' lifestyles, please indicate the interests and activities in which *you or your spouse* enjoy participating on a *regular* basis.

- | | | |
|--|---|--|
| 01. <input type="checkbox"/> Bicycling | 18. <input type="checkbox"/> Buy Prerecorded Videos | 35. <input type="checkbox"/> Wines |
| 02. <input type="checkbox"/> Golf | 19. <input type="checkbox"/> Automotive Work | 36. <input type="checkbox"/> Stamp/Coin Collecting |
| 03. <input type="checkbox"/> Physical Fitness/Exercise | 20. <input type="checkbox"/> Electronics | 37. <input type="checkbox"/> Collectibles |
| 04. <input type="checkbox"/> Running/Jogging | 21. <input type="checkbox"/> Home Workshop/Do-It-Yourself | 38. <input type="checkbox"/> Our Nation's Heritage |
| 05. <input type="checkbox"/> Snow Skiing | 22. <input type="checkbox"/> Recreation Vehicles (RVs) | 39. <input type="checkbox"/> Real Estate Investments |
| 06. <input type="checkbox"/> Tennis | 23. <input type="checkbox"/> Listen to Records/Tapes/CDs | 40. <input type="checkbox"/> Stocks/Bond Investments |
| 07. <input type="checkbox"/> Camping/Hiking | 24. <input type="checkbox"/> Avid Book Reading | 41. <input type="checkbox"/> Contests/Sweepstakes |
| 08. <input type="checkbox"/> Fishing | 25. <input type="checkbox"/> Bible/Devotional Reading | 42. <input type="checkbox"/> Casino Gambling |
| 09. <input type="checkbox"/> Hunting/Shooting | 26. <input type="checkbox"/> Health/Natural Foods | 43. <input type="checkbox"/> Science Fiction |
| 10. <input type="checkbox"/> Powerboating | 27. <input type="checkbox"/> Photography | 44. <input type="checkbox"/> Wildlife/Environmental Issues |
| 11. <input type="checkbox"/> Sailing | 28. <input type="checkbox"/> Cultural/Arts Events | 45. <input type="checkbox"/> Dieting/Weight Control |
| 12. <input type="checkbox"/> Grandchildren | 29. <input type="checkbox"/> Fashion Clothing | 46. <input type="checkbox"/> Science/New Technology |
| 13. <input type="checkbox"/> Needlework/Knitting | 30. <input type="checkbox"/> Art/Antique Collecting | 47. <input type="checkbox"/> Self-Improvement |
| 14. <input type="checkbox"/> Sewing | 31. <input type="checkbox"/> Foreign Travel | 48. <input type="checkbox"/> Walking for Health |
| 15. <input type="checkbox"/> Flower Gardening | 32. <input type="checkbox"/> Cruise Ship Vacations | 49. <input type="checkbox"/> Watching Sports on TV |
| 16. <input type="checkbox"/> Vegetable Gardening | 33. <input type="checkbox"/> Travel in USA | 50. <input type="checkbox"/> Home Video Recording |
| 17. <input type="checkbox"/> Crafts | 34. <input type="checkbox"/> Gourmet Cooking/Fine Foods | 51. <input type="checkbox"/> Moneymaking Opportunities |

28. Using the numbers in the above list, please indicate your 3 most important activities:

--	--	--

Thanks for taking the time to fill out this questionnaire. Your answers will be used for market research studies and reports. They will also allow you to receive important mailings and special offers from a number of fine companies whose products and services relate directly to the specific interests, hobbies, and other information indicated above. Through this selective program, you will be able to obtain more information about activities in which you are involved and less about those in which you are not. Please check here if, for some reason, you would prefer *not* to participate in this opportunity.

Failure to return this card will not diminish your warranty rights.

540-0026 (A)

Copyright © 2004 All Rights Reserved

Please seal with tape. Do not staple.

Please send products and other
correspondence to:

Directed Electronics Inc.
1 Viper Way
Vista, CA 92081



First-Class
Postage
Required
Post Office will
not deliver
without proper
postage.

XFA01-01

Directed
ELECTRONICS, INC.

PO BOX 174391
DENVER CO 80217-4391



PRODUCT REGISTRATION

Directed
ELECTRONICS, INC.
Audio/Video

RETURN THIS CARD NOW FOR:

- **Product Protection**

With the information you provide we can confirm the date of purchase of your product.
This confirmation is of benefit to you, especially if your original proof of purchase is lost.

- **Proof of Ownership**

Your model number, serial number, and other information will be kept in our files
for up to ten years.